

REPLACEMENT

HINT:

COMPONENTS: See page 55-33

1. DISCHARGE REFRIGERANT FROM REFRIGERATION SYSTEM (See page 55-11)

SST 07110-58060 (07117-58080, 07117-58090, 07117-78050, 07117-88060, 07117-88070, 07117-88080)

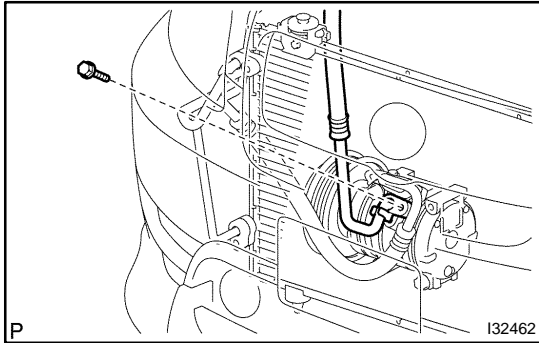

2. DISCONNECT COOLER REFRIGERANT SUCTION HOSE NO.1

- (a) Remove the bolt and disconnect the cooler refrigerant suction hose No.1 from the compressor and magnetic clutch.
- (b) Remove the O-ring from the cooler refrigerant suction hose No.1.

NOTICE:

Seal the opening of the disconnected parts using vinyl tape to prevent moisture and foreign matter from entering.

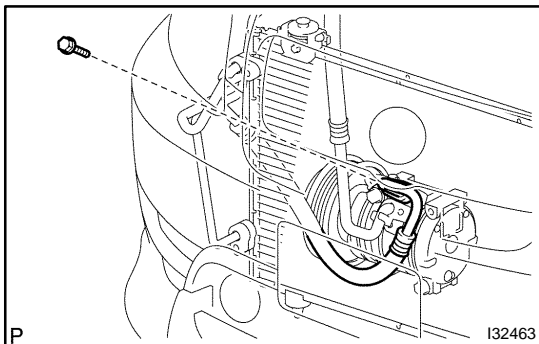

3. DISCONNECT DISCHARGE HOSE SUB-ASSY

- (a) Remove the bolt and disconnect the discharge hose sub-assy from the compressor and magnetic clutch.
- (b) Remove the O-ring from the discharge hose sub-assy.

NOTICE:

Seal the opening of the disconnected parts using vinyl tape to prevent moisture and foreign matter from entering.

4. REMOVE ENGINE UNDER COVER RH

5. REMOVE FAN AND GENERATOR V BELT (See page 14-177)

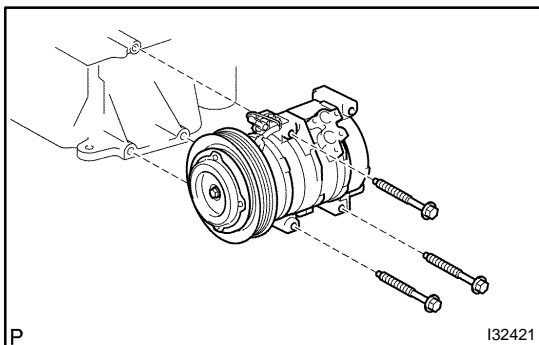

6. REMOVE COMPRESSOR AND MAGNETIC CLUTCH

- (a) Disconnect the connector.
- (b) Remove the 3 bolts and compressor and magnetic clutch.

7. REMOVE MAGNET CLUTCH ASSY

- (a) Place the compressor and magnetic clutch in vise.

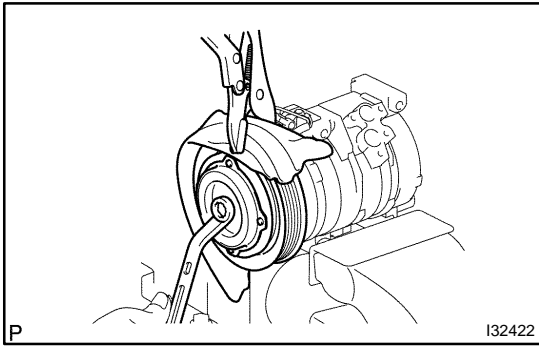

- (b) Using a vise pliers, hold the magnet clutch hub.
- (c) Remove the bolt, magnet clutch hub and magnet clutch washer.

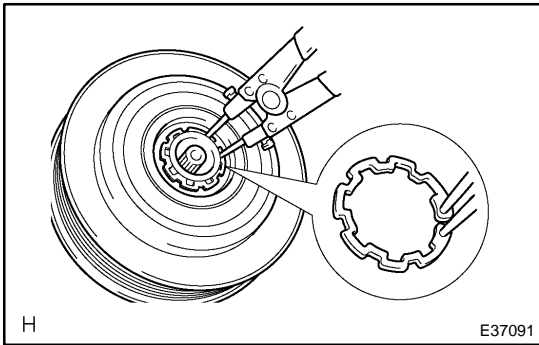

- (d) Using a snap ring expander, remove the snap ring and magnet clutch rotor.
- (e) Remove the screw, disconnect the connector.

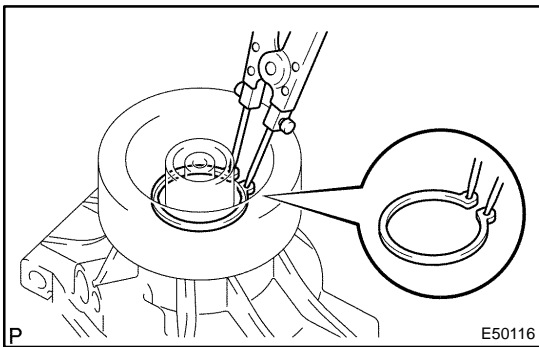

- (f) Using a snap ring expander, remove the snap ring and magnet clutch starter.

8. REMOVE COOLER COMPRESSOR ASSY

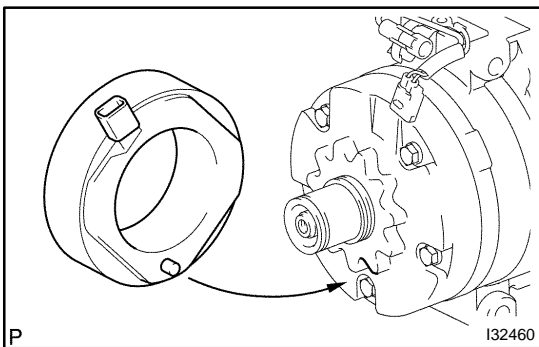

9. INSTALL MAGNET CLUTCH ASSY

- (a) Matching the parts shown in the illustration, install the magnet clutch starter.

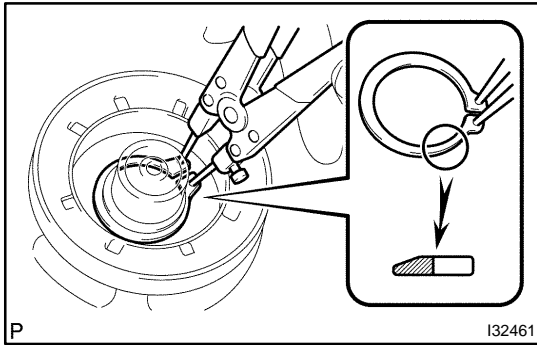

- (b) Using a snap ring expander, install a new snap ring with the chamfered side facing up.
- (c) Install the screw, connect the connector.

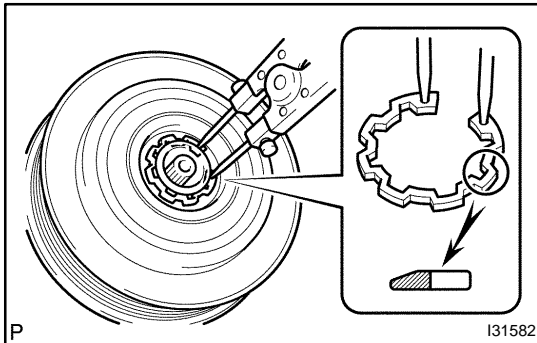

- (d) Using a snap ring expander, install the magnet clutch rotor and a new snap ring with the chamfered side facing up.
- (e) Install the magnet clutch washer and magnet clutch hub.

NOTICE:

Do not change the combination of the magnet clutch washers used before disassembly.

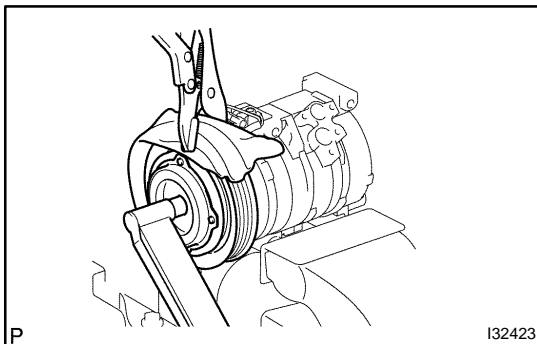

- (f) Using a vise pliers, hold the magnet clutch hub and install the bolt.

Torque: 18 N·m (183 kgf·cm, 13 ft·lbf)

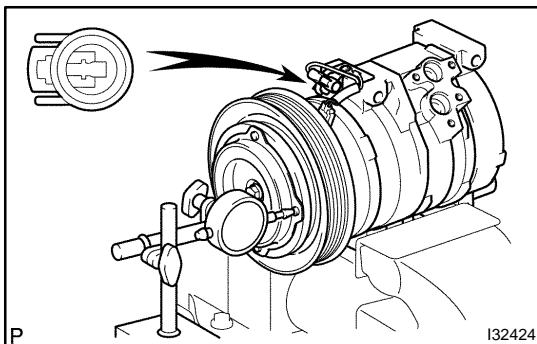
**10. INSPECT MAGNETIC CLUTCH CLEARANCE**

- (a) Set the dial indicator to the magnet clutch hub.
- (b) Connect the battery positive lead to the terminal 1 of magnet clutch connector and the negative lead to the earth wire. Turn on and off the magnet clutch and measure the clearance.

Standard clearance:

0.35 – 0.60 mm (0.013 – 0.023 in.)

If the measured value is out of the standard range, remove the magnet clutch hub and adjust it with magnet clutch washers.

NOTICE:

Adjustment shall be performed with 3 or less magnet clutch washers.

11. INSPECT COMPRESSOR OIL

- (a) When replacing the compressor and magnetic clutch with new one, after gradually removing the refrigerant gas from the service valve, drain the following amount of oil from the new compressor and magnetic clutch before installation.

Standard:

(Oil capacity inside new compressor and magnetic clutch: 120 + 15 cc (4.0 + 0.5 fl. oz.)) – (Remaining oil amount in the removed compressor and magnetic clutch) = (Oil amount to be removed when replacing)

NOTICE:

- When checking the compressor oil level, observe the precautions on the cooler removal/installation.
- Because compressor oil remains in the pipes of the vehicle, if a new compressor and magnetic clutch is installed without removing some oil inside, the oil amount becomes too much, preventing heat exchange in the refrigerant cycle and causing refrigerant failure.
- If the remaining oil in the removed compressor and magnetic clutch is too small in volume, check for oil leakage.
- Be sure to use ND-OIL8 for compressor oil.

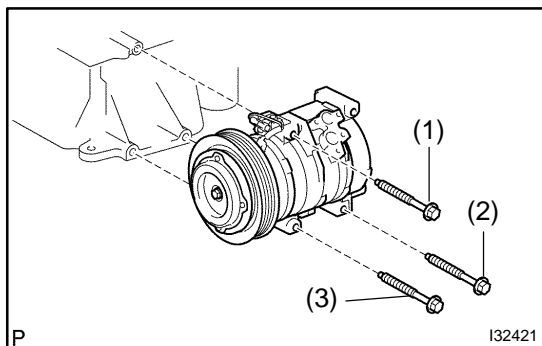
**12. INSTALL COMPRESSOR AND MAGNETIC CLUTCH**

- (a) Install the compressor and magnetic clutch with the 3 bolts.

Toque: 29 N·m (295 kgf·cm, 21 ft·lbf)

NOTICE:

Tighten the bolts in following order shown in the illustration to install the compressor and magnetic clutch.

- (b) Connect the connector.

13. INSTALL DISCHARGE HOSE SUB-ASSY

- (a) Remove the attached vinyl tape from the hose.
 (b) Sufficiently apply compressor oil to the new O-ring and fit surface of the compressor and magnetic clutch.

Compressor oil: ND-OIL8 or equivalent

- (c) Install a O-ring to the discharge hose sub-assy.

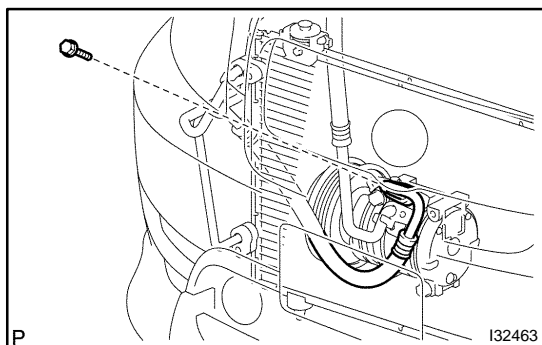

- (d) Install the discharge hose sub-assy to the compressor and magnetic clutch with the bolt.

Torque: 9.8 N·m (100 kgf·cm, 87 in·lbf)

14. INSTALL COOLER REFRIGERANT SUCTION HOSE NO.1

- (a) Remove the attached vinyl tape from the hose.
- (b) Sufficiently apply compressor oil to the new O-ring and fit surface of the compressor and magnetic clutch.

Compressor oil: ND-OIL8 or equivalent

- (c) Install a O-ring to the cooler refrigerant suction hose No.1.

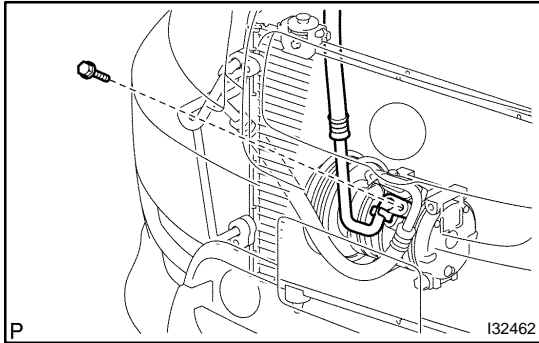

- (d) Install the cooler refrigerant suction hose No.1 to the compressor and magnetic clutch with the bolt.

Torque: 9.8 N·m (100 kgf·cm, 87 in·lbf)

15. CHARGE REFRIGERANT (See page 55-11)

SST 07110-58060 (07117-58060, 07117-58070, 07117-58080, 07117-58090, 07117-78050, 07117-88060, 07117-88070, 07117-88080), 07117-48130, 07117-48140

Specified amount: 470 ± 30 g (17.28 ± 1.06 oz.)

16. WARM UP ENGINE**17. INSPECT LEAKAGE OF REFRIGERANT (See page 55-11)**