

TRANSMISSION VALVE BODY ASSY (U341F)

400N2-01

REPLACEMENT

1. REMOVE ENGINE UNDER COVER LH
2. DRAIN AUTOMATIC TRANSAXLE FLUID
 - (a) Remove the drain plug and gasket, and drain ATF.
 - (b) Install a new gasket and drain plug.
Torque: 49 N·m (500 kgf·cm, 36 ft·lbf)

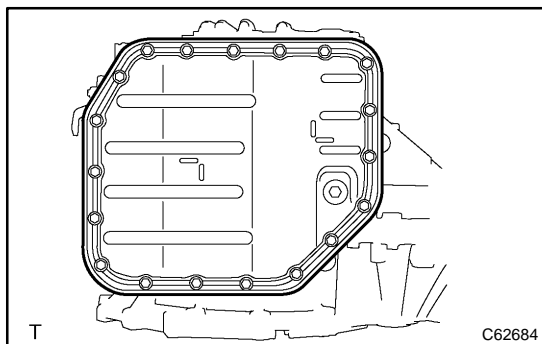

3. REMOVE AUTOMATIC TRANSAXLE OIL PAN SUB-ASSY

- (a) Remove the 19 bolts, oil pan and gasket.

NOTICE:

Some fluid will remain in the oil pan. Remove all pan bolts, and carefully remove the oil pan assembly. Discard the gasket.

- (b) Remove the 2 magnets from the oil pan.

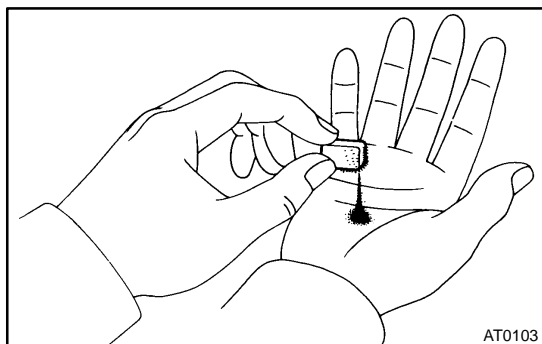

- (c) Examine particles in pan.

- (1) Remove the magnets and use them to collect any steel chips. Look carefully at the chips and particles in the pan and the magnet to anticipate what type of wear you will find in the transaxle.
Steel (magnetic): bearing, gear and plate wear
Brass (non-magnetic): bearing wear

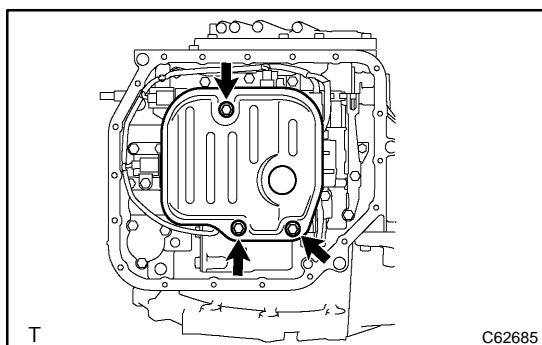

4. REMOVE VALVE BODY OIL STRAINER ASSY

- (a) Remove the 3 bolts and oil strainer.

NOTICE:

Be careful as some fluid will come out with the oil strainer.

- (b) Remove the O-ring from the oil strainer.

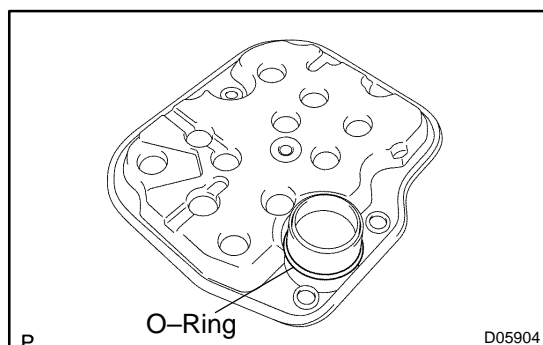

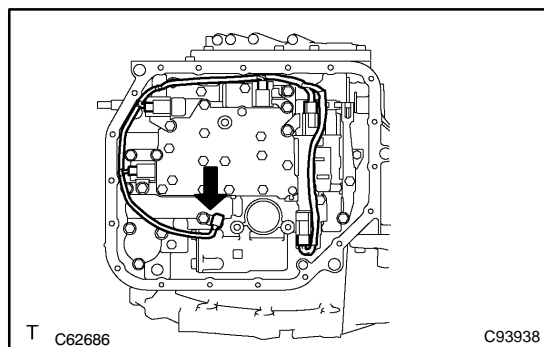
**5. REMOVE TRANSMISSION VALVE BODY ASSY**

- (a) Disconnect the 5 connectors.
- (b) Remove the bolt and lock plate, and remove the ATF temperature sensor.

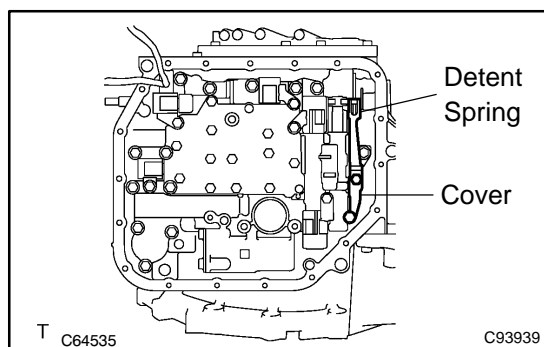

- (c) Remove the 2 bolts, cover and detent spring.

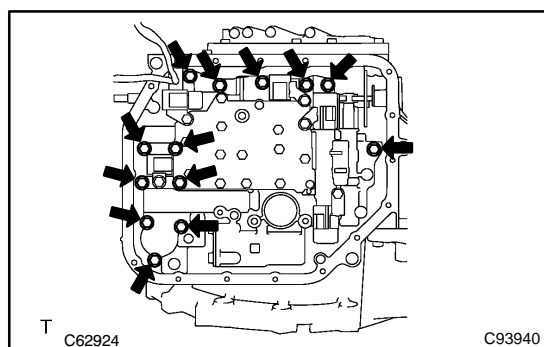

- (d) Remove the 13 bolts and valve body.

NOTICE:

Be careful not to drop the check valve body, spring and accumulator piston.

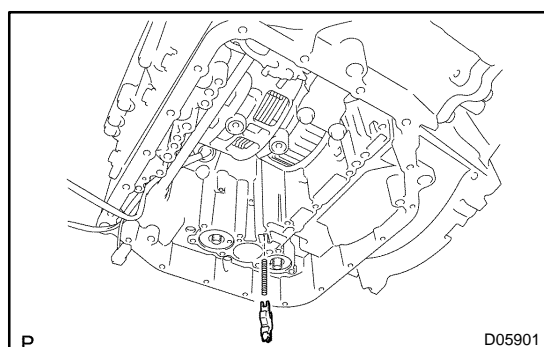

- (e) Remove the check ball body and spring.

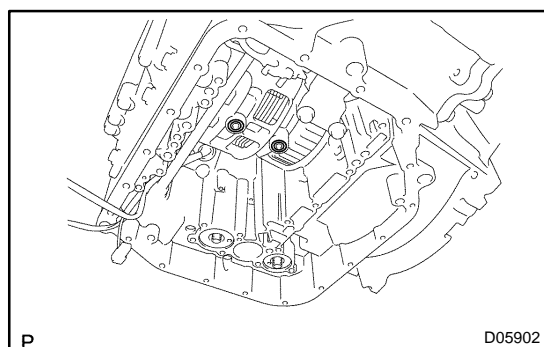

- (f) Remove the 2 apply gaskets.

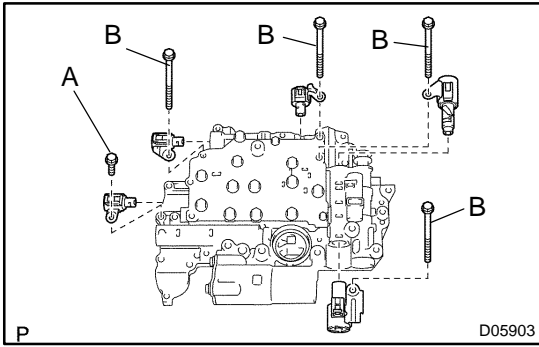

(g) Remove the 5 bolts and 5 shift solenoid valves.

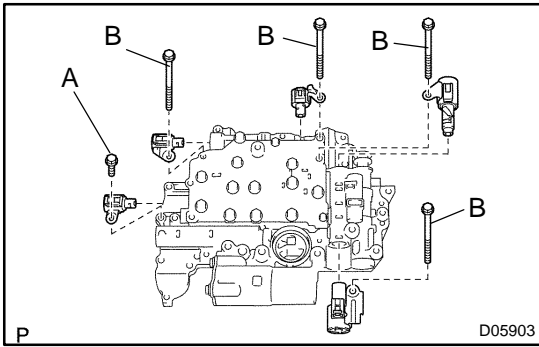

6. INSTALL TRANSMISSION VALVE BODY ASSY

(a) Install the 5 shift solenoid valves with the 5 bolts.

Torque:

Bolt A: 10.8 N·m (110 kgf·cm, 8 ft ·lbf)

Bolt B: 10.8 N·m (110 kgf·cm, 8 ft ·lbf)

Bolt length:

Bolt A: 14 mm (0.55 in.)

Bolt B: 55 mm (2.17 in.)

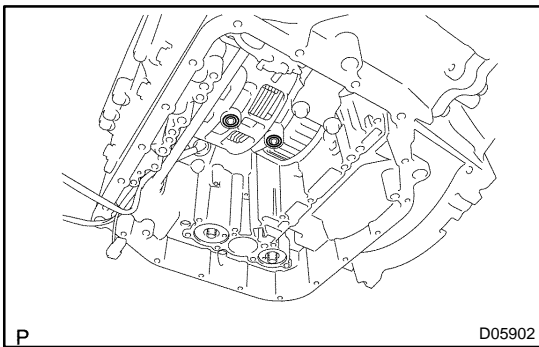

(b) Coat 2 new apply gaskets with ATF.

(c) Install the gaskets to the transaxle case.

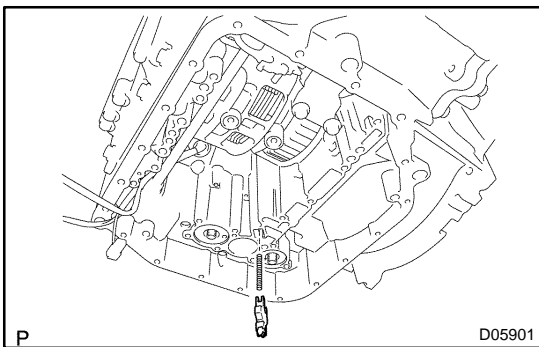

(d) Install the spring and check ball body.

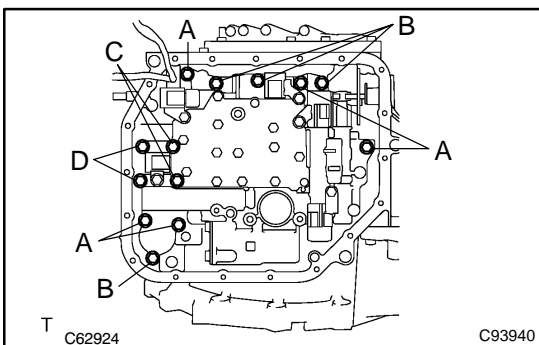

(e) Align the groove of the manual valve with the pin of the manual valve lever.

(f) Temporarily install the valve body with the 13 bolts.

Bolt length:

Bolt A: 32 mm (1.26 in.)

Bolt B: 22 mm (0.87 in.)

Bolt C: 55 mm (2.17 in.)

Bolt D: 45 mm (1.77 in.)

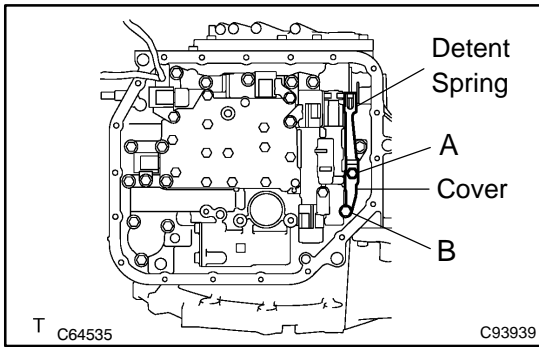

- (g) Temporarily install the detent spring and cover with the 2 bolts.
Bolt length:
Bolt A: 14 mm (0.55 in.)
Bolt B: 45 mm (1.77 in.)
- (h) Check that the manual valve lever contacts the center of the roller at the tip of the detent spring.
- (i) Tighten the 15 bolts.
Torque: 10.8 N·m (110 kgf·cm, 8 ft·lbf)

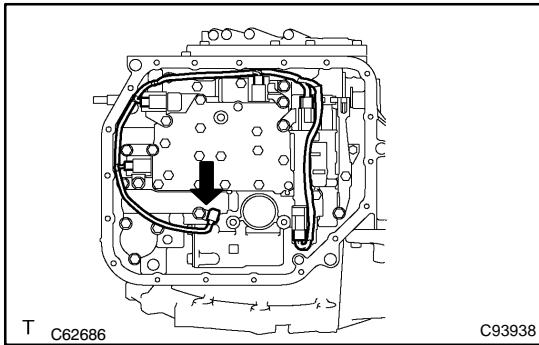

- (j) Install the ATF temperature sensor with the lock plate and bolt.
Torque: 10.8 N·m (110 kgf·cm, 8 ft·lbf)
- (k) Connect the 5 shift solenoid valve connectors.

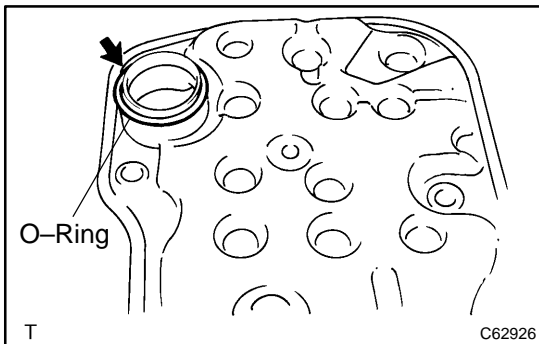

7. INSTALL VALVE BODY OIL STRAINER ASSY

- (a) Coat a new O-ring with ATF.
- (b) Install the O-ring to the oil strainer.

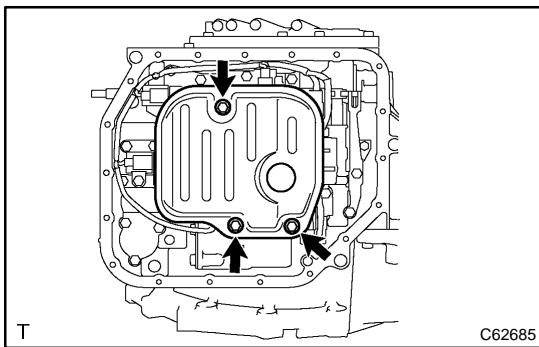

- (c) Install the oil strainer with the 3 bolts.
Torque: 10.8 N·m (110 kgf·cm, 8 ft·lbf)

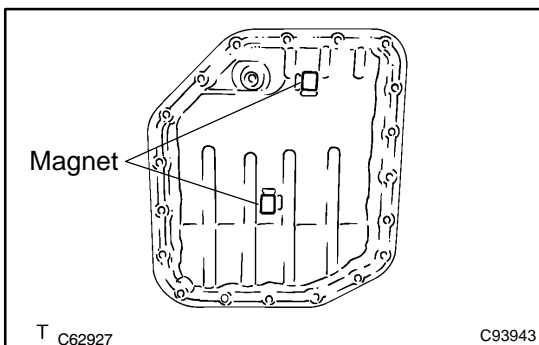

8. INSTALL AUTOMATIC TRANSAXLE OIL PAN SUB-ASSY

- (a) Install the 2 magnets in the oil pan, as shown in the illustration.
- (b) Install a new gasket to the oil pan.

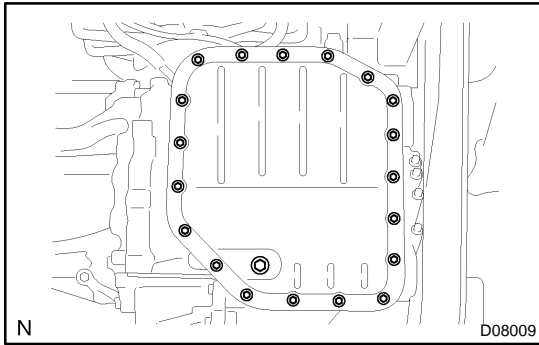

- (c) Install the oil pan and a new gasket with the 19 bolts.
Torque: 7.8 N·m (80 kgf·cm, 69 in.-lbf)

9. **INSTALL ENGINE UNDER COVER LH**
10. **ADD AUTOMATIC TRANSAXLE FLUID**
11. **INSPECT AUTOMATIC TRANSAXLE FLUID (See page [40-2](#))**