

REPLACEMENT

1. DRAIN ENGINE OIL

- (a) Remove the oil pan drain plug and drain the engine oil.

2. REMOVAL & INSTALLATION CHAIN SUB-ASSY(See page 14-247)

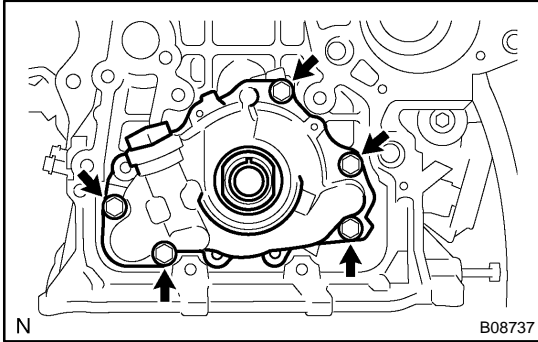

3. REMOVE OIL PUMP ASSY

- (a) Remove the 5 bolts.
(b) Remove the oil pump assy and gasket.

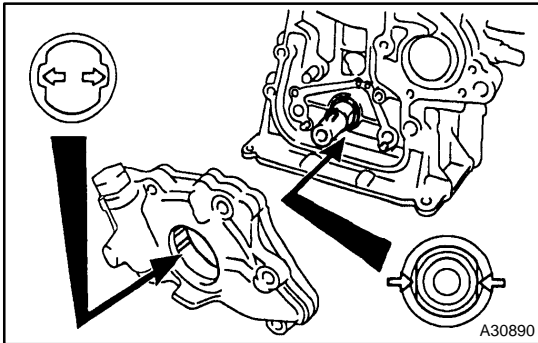

4. INSTALL OIL PUMP ASSY

- (a) Place a new gasket on the cylinder block.
(b) Engage the spline teeth of the oil pump drive rotor with the large teeth of the crankshaft, and side the oil pump.
(c) Install the oil pump with the 5 bolts.

Torque: 9.0 N·m (92 kgf·cm, 80 in.-lbf)

5. INSTALL OIL PAN DRAIN PLUG

- (a) Clean and install the oil pan drain plug with a new gasket.

Torque: 37 N·m (377 kgf·cm, 27 ft·lbf)

6. ADD ENGINE OIL

Capacity:

Drain and refill w/ Oil filter change 4.4 liters (4.7 US qts, 3.9 Imp. qts)

Drain and refill w/o Oil filter change 4.2 liters (4.4 US qts, 3.7 Imp. qts)

Dry fill 4.8 liters (5.1 US qts, 4.2 Imp. qts)

7. ADD COOLANT(See page 16-6)

8. INSPECT OIL LEAK

9. INSPECT CHECK ENGINE COOLANT LEAK(See page 16-1)