

# INSPECTION

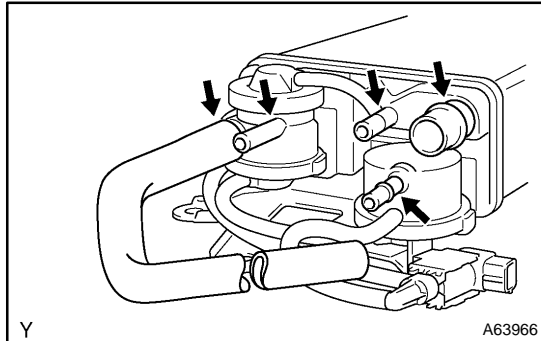

## 1. CHARCOAL CANISTER ASSY

- (a) Visually check the charcoal canister for cracks or damage.

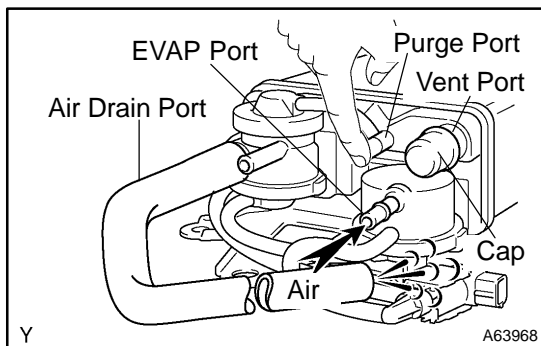

- (b) Inspect the charcoal canister operation.

- (1) Plug the vent port with the cap.
- (2) While holding the purge port closed, blow air (1.76 kPa, 18 gf/cm<sup>2</sup>, 0.26 psi) into the EVAP port and check that air flows from the air drain port.

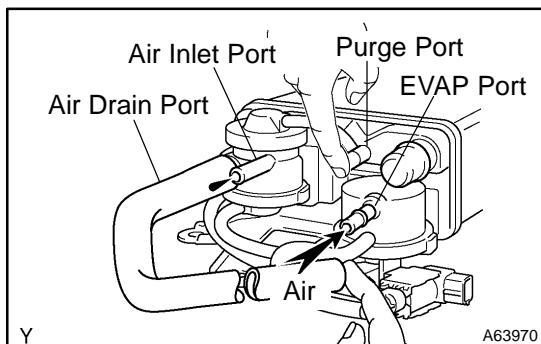

- (3) While holding the purge port and the air drain port closed, blow air (1.76 kPa, 18 gf/cm<sup>2</sup>, 0.26 psi) into the EVAP port and check that air does not flow from the air inlet port.

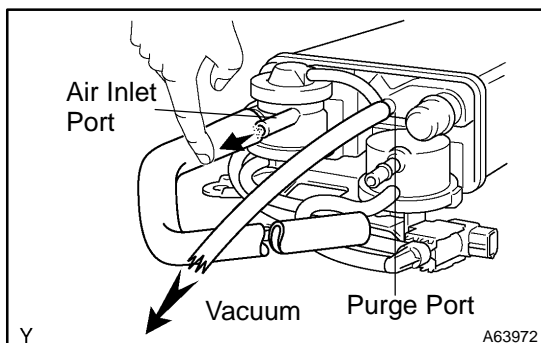

- (4) Apply vacuum (3.43 kPa, 25.7 mmHg, 1.01 in.Hg) to the purge port, check that the vacuum does not decrease when the air inlet port is closed, and check that the vacuum decreases when the air inlet port is released.

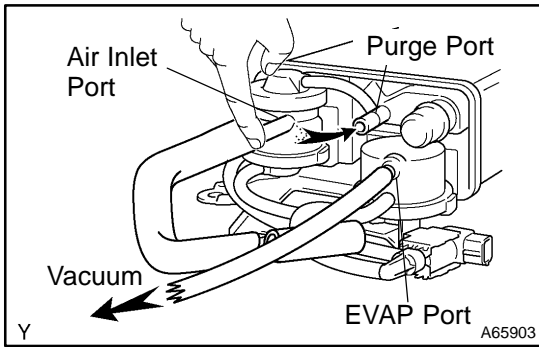

- (5) While holding the air inlet port closed, apply vacuum (3.43 kPa, 25.7 mmHg, 1.01 in.Hg) to the EVAP port and check that air flows into the purge port.

If operation is not as specified, replace the charcoal canister.

- (6) Remove the hose and cap from vent port.

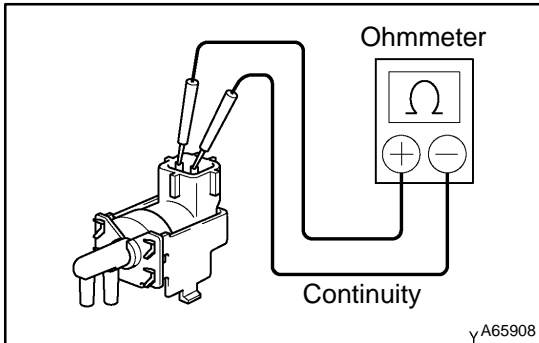

- (c) Inspect VSV for Pressure Switching Valve

- (1) Using an ohmmeter, check that there is continuity between the terminals.

**Resistance: 37 – 44 Ω at 20°C (68°F)**

If there is no continuity, replace the VSV.

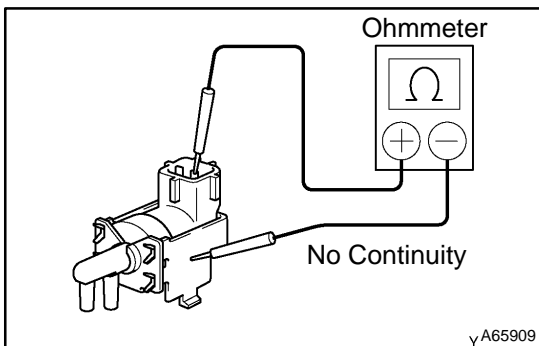

- (2) Using an ohmmeter, check that there is no continuity between each terminal and the body.

If there is continuity, replace the VSV.

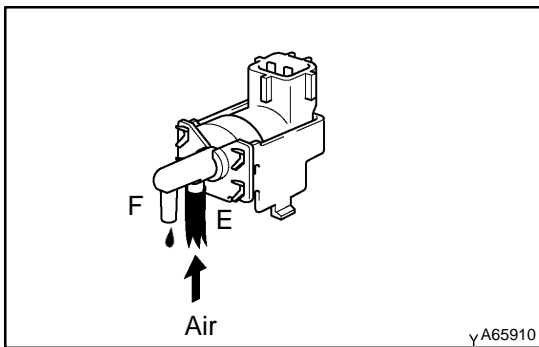

- (3) Check that air does not flow from ports E to F.

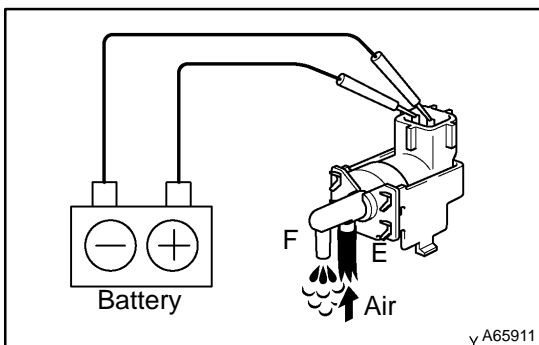

- (4) Apply battery positive voltage across the terminals.

- (5) Check that air flows from ports E to F.

If operation is not as specified, replace the VSV.

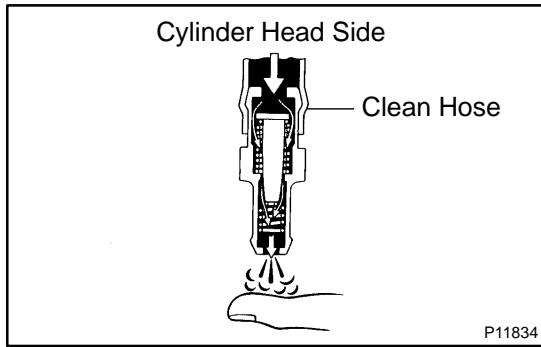

## 2. VENTILATION VALVE SUB-ASSY

- (a) Install clean hose to the PCV valve.
- (b) Inspect the PCV valve operation.
  - (1) Blow air into the cylinder head side, and check that air passes through easily.

### CAUTION:

**Do not suck air through the valve. Petroleum substances inside the valve air harmful.**

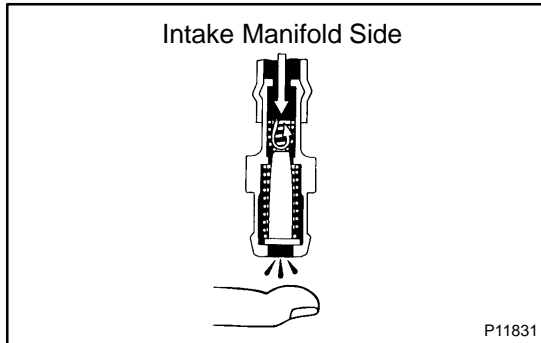

- (2) Blow air into the intake manifold side, and check that air passes through with difficulty.

If operation is not as specified, replace the PCV valve.

- (c) Remove clean hose from the PCV valve.

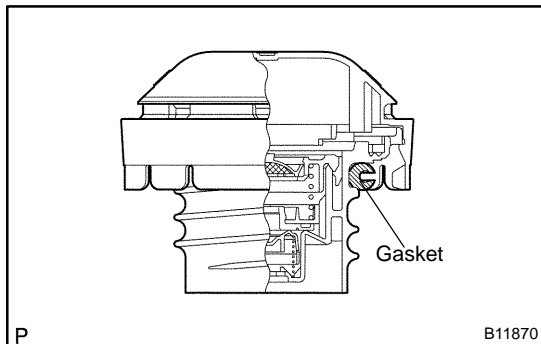

## 3. FUEL TANK CAP ASSY

- (a) Visually check if cap and/or gasket are deformed or damaged.

If necessary, repair or replace the cap.

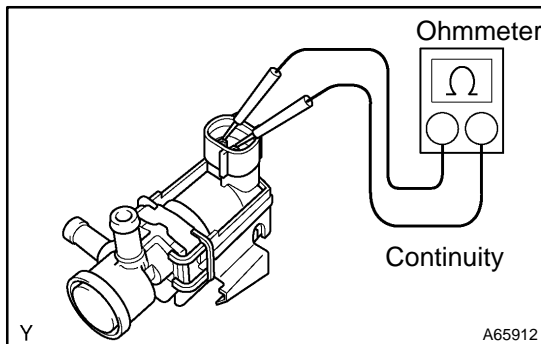

## 4. VACUUM SWITCHING VALVE NO.1

- (a) Inspect VSV for evaporative emission (EVAP).
  - (1) Using an ohmmeter, check that there is continuity between the terminals.

**Resistance: 27 – 33  $\Omega$  at 20°C (68°F)**

If there is no continuity, replace the VSV.

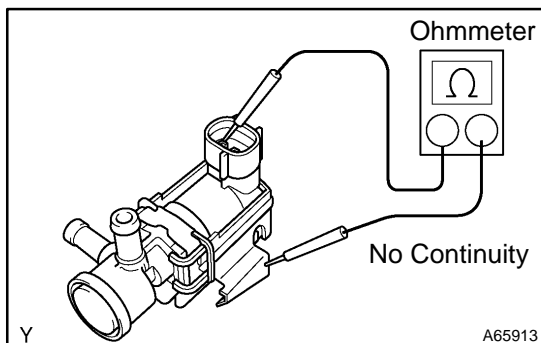

- (2) Using an ohmmeter, check that there is no continuity between each terminal and the body.

If there is continuity, replace the VSV.

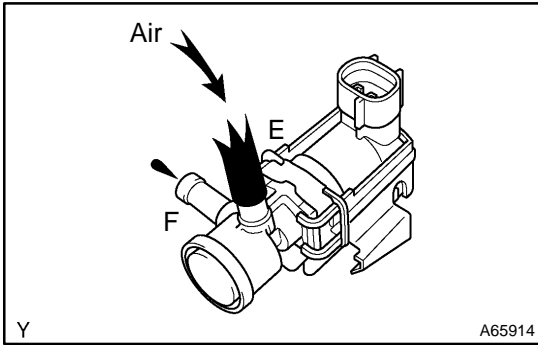

(3) Check that air flows from ports E to F.

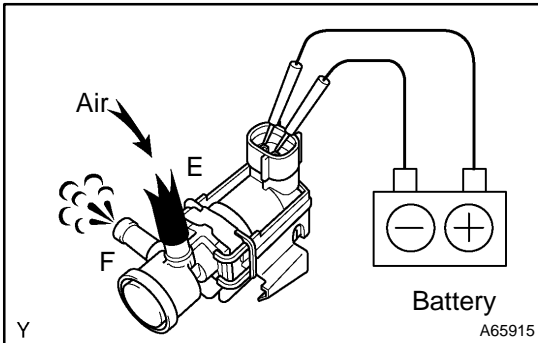

(4) Apply battery positive voltage across the terminals.

(5) Check that air does not flow from ports E to F.

If operation is not as specified, replace the VSV.

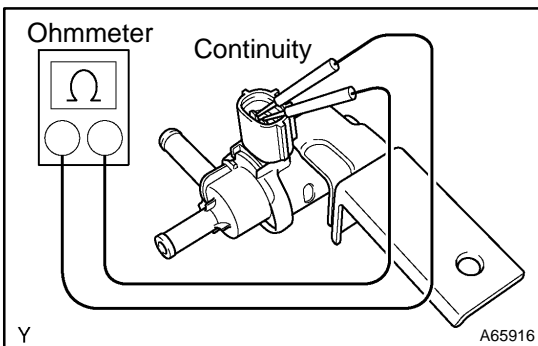

**5. VACUUM SWITCHING VALVE ASSY NO.1**

(a) Inspect VSV for Canister Closed valve (CCV).

(1) Using an ohmmeter, check that there is continuity between the terminals.

**Resistance: 25 – 30 Ω at 20°C (68°F)**

If there is no continuity, replace the VSV.

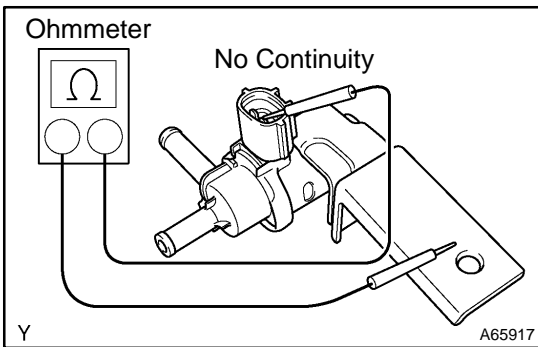

(2) Using an ohmmeter, check that there is no continuity between each terminal and the body.

If there is continuity, replace the VSV.

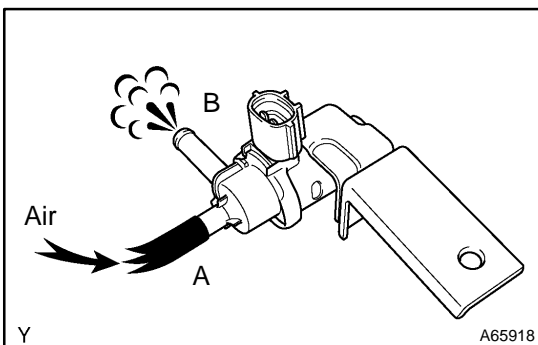

(3) Check that air flows from ports A to B.

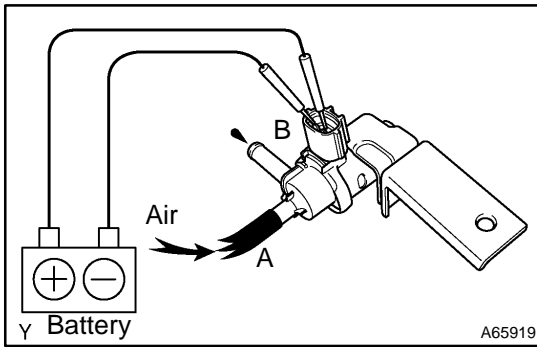

- (4) Apply battery positive voltage across the terminals.
  - (5) Check that air does not flow from ports A to B.
- If operation is not as specified, replace the VSV.